

---

# KPS - KPF - KP

## PERIPHERAL PUMPS



KPS 30/16



KPF 30/16

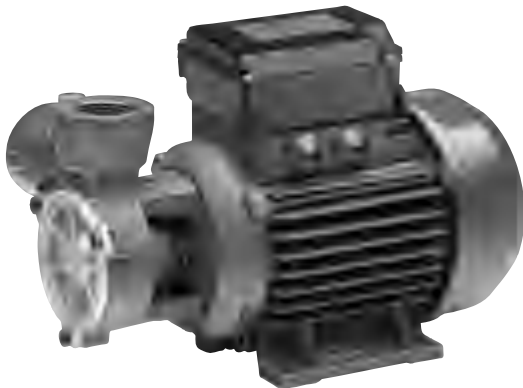

KP 38/18



KP 60/6 - KP 60/12



---

## GENERAL DATA

### Applications

Peripheral centrifugal pump with compact dimensions. Able to generate high heads and suitable for domestic installations, water supply systems, small gardening applications, draining and filling cisterns, and for small industrial uses such as feeding pressurized boilers (anti-condensation).

### Constructional features of the pump

Brass pump body and motor support for KP 60/6 and KP 60/12.  
Cast iron pump body with radial suction for KPS, frontal suction for KPF.  
Motor support with brass wear disc for KPS 30/16 and KP 38/18.  
KPS 30/16 is available on request with pump body and support in bronze.  
Brass impeller.  
Carbon/ceramic mechanical seal.

### Constructional features of the motor

Induction motor, closed and cooled with external ventilation.  
Rotor mounted on oversized greased sealed-for-life ball bearings to ensure silent running and long life.  
Built-in thermal and current overload protection and a capacitor permanently in circuit in the single-phase version.  
Three-phase motors should be protected with a suitable overload protection complying with the regulations in force.  
Manufactured according to CEI 2-3 and CEI 61-69 standards (EN 60335-2-41).  
Motor protection: IP44  
Terminal box protection: IP55  
Insulation class: F  
Standard voltage: single-phase 220-240 V/50 Hz  
                          three-phase 230-400 V/50 Hz

# TECHNICAL DATA

N.	PARTS*	MATERIALS
1	PUMP BODY	CAST IRON 200 UNI ISO 185
4	IMPELLER	BRASS PCu Zn 40 Pb2 UNI 5705/65
7	SHAFT WITH ROTOR	STAINLESS STEEL AISI 416 X12 CrS 13 UNI 6900/71
16	MECHANICAL SEAL	CARBON/CERAMIC
28	OR GASKET	NBR
33	COVER	BRASS PCu Zn 40 Pb2 UNI 5705/65

\* In contact with the liquid.

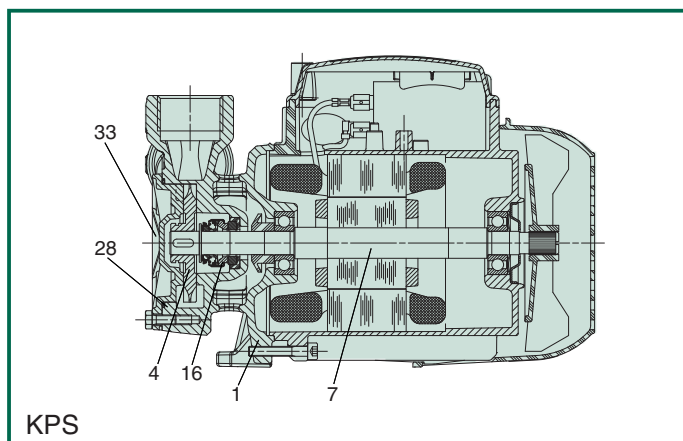

- Operating range: from 5 to 36 l/min with head up to 33 metres
- Liquid quality requirements: clean, free from solids or abrasive substances, non viscous, non aggressive, non crystallized, chemically neutral, close to the characteristics of water.
- Liquid temperature range: from 0°C to +35°C for domestic use (EN 60335-2-41)  
from -10°C to +50°C for other uses
- Maximum ambient temperature: +40°C
- Maximum operating pressure: 6 bar (600 kPa)
- Installation: fixed in a horizontal position
- Special executions on request: other voltages and/or frequencies

The performance curves are based on the kinematic viscosity values = 1 mm<sup>2</sup>/s and density equal to 1000 kg/m<sup>3</sup>. Curve tolerance according to ISO 9906.

## KPS 30/16

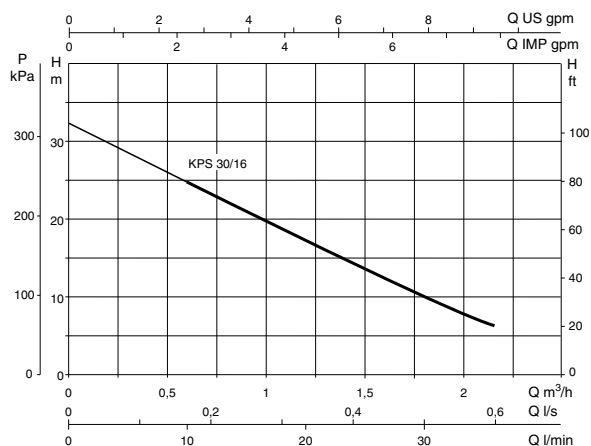
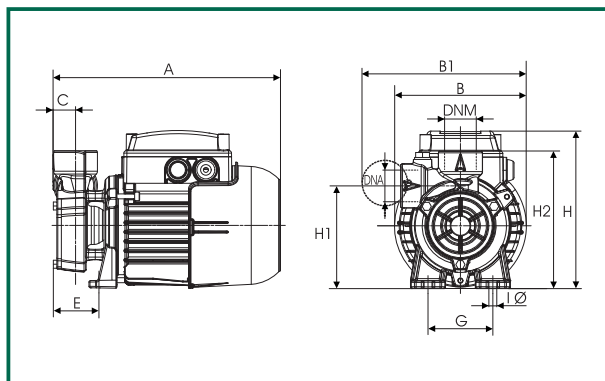

MODEL	A	B	B1	C	E	F	G	I Ø	H	H1	H2	DNA	DNM	PACKING DIMENSIONS			VOLUME	WEIGHT
														L/A	L/B	H	m <sup>3</sup>	Kg
<b>KPS 30/16</b>	228	132	165	22	46	-	65	8	158	103	138	1" G	1" G	259	164	197	0,008	5,3

MODEL	ELECTRICAL DATA							HYDRAULIC DATA (n ≈ 2800 1/min)							
	VOLTAGE 50 Hz	P1 MAX kW	P2 NOMINAL		In A	CAPACITOR		Q m³/h	0	0,3	0,6	0,9	1,2	1,8	2,16
			kW	HP		µF	Vc	l/min	0	5	10	15	20	30	36
<b>KPS 30/16 M</b>	1x220-240 V ~	0,47	0,37	0,5	2	8	450	H (m)	32,5	28	25	22	17,5	10	6
<b>KPS 30/16 T</b>	3x230-400 V ~	0,47	0,37	0,5	1,4-0,8	-	-								

KPS 30/16 M are available on request: equipped with gauge, pressure switch, power cable and plug plus a three-way connection for connecting to a tank.

# TECHNICAL DATA

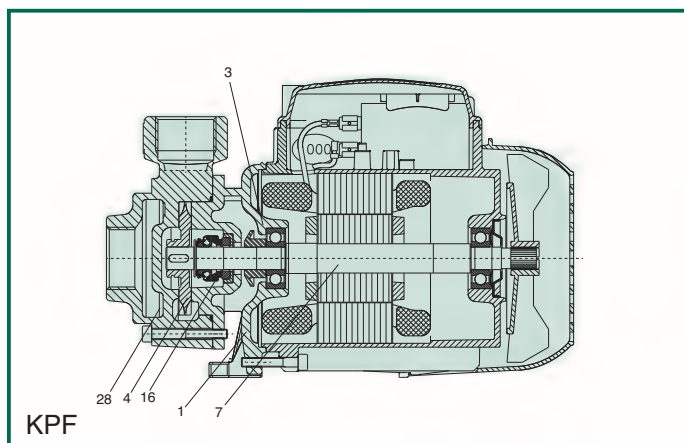

N.	PARTS*	MATERIALS
1	PUMP BODY	G20 EN-GJL-250 UNI EN 1561
3	SUPPORT	G20 EN-GJL-250 UNI EN 1561
4	IMPELLER	BRASS PCu Zn 40 Pb2 UNI 5705/65
7	SHAFT WITH ROTOR	STAINLESS STEEL AISI 416 X12 CrS 13 UNI 6900/71
16	MECHANICAL SEAL	CARBON/CERAMIC
28	OR GASKET	NBR

\* In contact with the liquid.

- Operating range: from 5 to 36 l/min with head up to 33 metres
- Liquid quality requirements: clean, free from solids or abrasive substances, non viscous, non aggressive, non crystallized, chemically neutral, close to the characteristics of water.
- Liquid temperature range: from 0°C to +35°C for domestic use (EN 60335-2-41)  
from -10°C to +50°C for other uses
- Maximum ambient temperature: +40°C
- Maximum operating pressure: 6 bar (600 kPa)
- Installation: fixed in a horizontal position
- Special executions on request: other voltages and/or frequencies

The performance curves are based on the kinematic viscosity values = 1 mm<sup>2</sup>/s and density equal to 1000 kg/m<sup>3</sup>. Curve tolerance according to ISO 9906.

## KPF 30/16

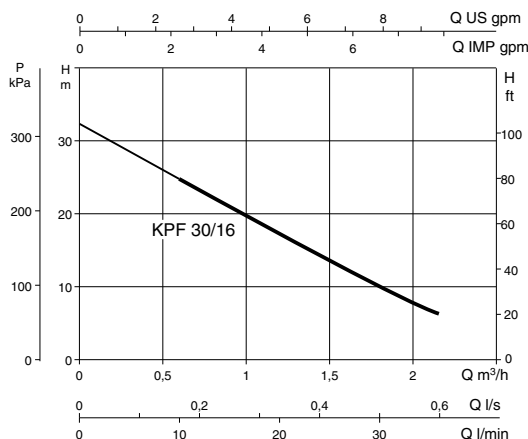
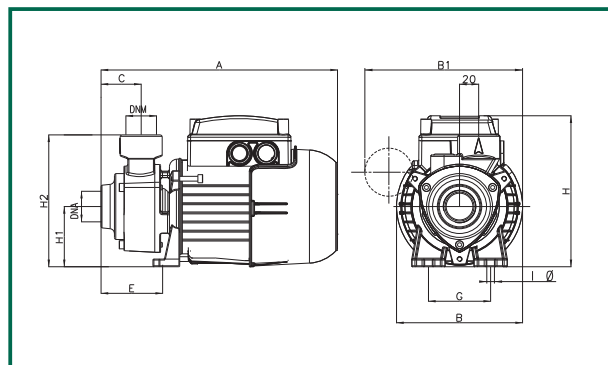

MODEL	A	B	B1*	C	E	F	G	IØ	H	H1	H2	DNA	DNM	PACKING DIMENSIONS			VOLUME	WEIGHT
														L/A	L/B	H	m <sup>3</sup>	kg
<b>KPF 30/16</b>	247	132	165	42	64	-	65	8	158	63	138	1" G	1" G	262	140	180	0,0083	5,4

\* only for the single-phase 110V - 50Hz model

MODEL	ELECTRICAL DATA					HYDRAULIC DATA (n ≈ 2800 1/min)									
	VOLTAGE 50 Hz	P1 MAX kW	P2 NOMINAL		In A	CAPACITOR		Q m <sup>3</sup> /h l/min	0	0,3	0,6	0,9	1,2	1,8	2,16
<b>KPF 30/16 M</b>	1x220-240 V ~	0,53	0,37	0,5	2,37	8	450	H (m)	32,5	31	25	22	17,5	10	6
<b>KPF 30/16 T</b>	3x230/400 V ~	0,47	0,37	0,5	1,45-0,82	-	-								

# TECHNICAL DATA

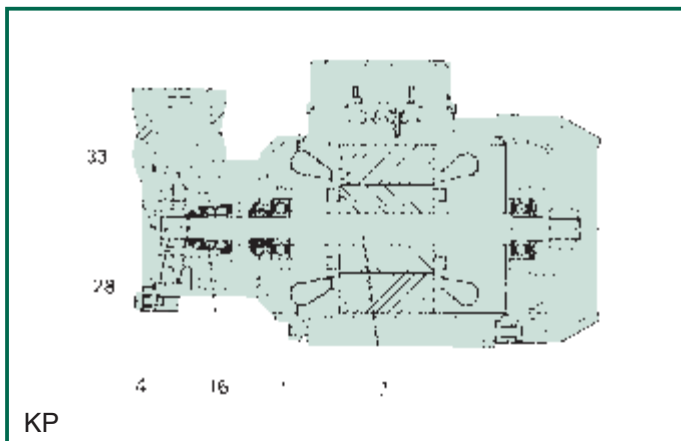

N.	PARTS*	MATERIALS
1	PUMP BODY	CAST IRON 200 UNI ISO 185
4	IMPELLER	BRASS PCu Zn 40 Pb2 UNI 5705/65
7	SHAFT WITH ROTOR	STAINLESS STEEL AISI 416 X12 CrS 13 UNI 6900/71
16	MECHANICAL SEAL	CARBON/CERAMIC
28	OR GASKET	NBR
33	COVER	BRASS PCu Zn 40 Pb2 UNI 5705/65

\* In contact with the liquid.

- Operating range: from 10 to 50 l/min with head up to 55 metres
- Liquid quality requirements: clean, free from solids or abrasive substances, non viscous, non aggressive, non crystallized, chemically neutral, close to the characteristics of water.
- Liquid temperature range: from 0°C to +35°C for domestic use (EN 60335-2-41)  
from -10°C to +50°C for other uses
- Maximum ambient temperature: +40°C
- Maximum operating pressure: 10 bar (1000 kPa)
- Installation: fixed in a horizontal position
- Special executions on request: other voltages and/or frequencies

The performance curves are based on the kinematic viscosity values = 1 mm<sup>2</sup>/s and density equal to 1000 kg/m<sup>3</sup>. Curve tolerance according to ISO 9906.

## KP 38/18

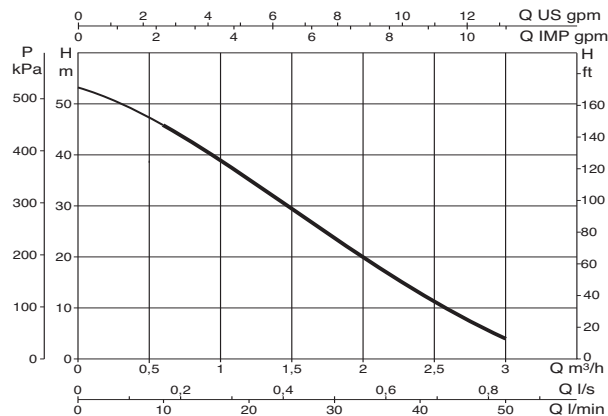
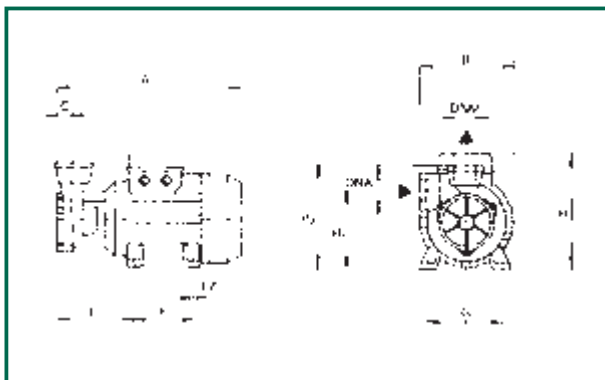

MODEL	A	B	B1	C	E	F	G	IØ	H	H1	H2	DNA	DNM	PACKING DIMENSIONS			VOLUME	WEIGHT
														L/A	L/B	H	m <sup>3</sup>	Kg
<b>KP 38/18</b>	255	130	-	26	106	80	100	7	186	108	153	1" G	1" G	271	176	209	0,01	7,5

MODEL	ELECTRICAL DATA							HYDRAULIC DATA (n ≈ 2800 1/min)											
	VOLTAGE 50 Hz	P1 MAX kW	P2 NOMINAL		In A	CAPACITOR		Q m³/h l/min	H										
			kW	HP		µF	Vc		0	0,3	0,6	0,9	1,2	1,8	2,4	3			
<b>KP 38/18 M</b>	1x220-240 V ~	0,89	0,6	0,8	4	12,5	450	53	50	46	41	35	24	14	4				
<b>KP 38/18 T</b>	3x230-400 V ~	0,86	0,6	0,8	2,9-1,7	-	-												

# TECHNICAL DATA

N.	PARTS*	MATERIALS
1	PUMP BODY	BRASS PCu Zn 40 Pb2 UNI 5705/65
3	SUPPORT	BRASS PCu Zn 40 Pb2 UNI 5705/65
4	IMPELLER	BRASS PCu Zn 40 Pb2 UNI 5705/65
7	SHAFT WITH ROTOR	STAINLESS STEEL AISI 416 X12 CrS 13 UNI 6900/71
16	MECHANICAL SEAL	CARBON/CERAMIC
28	OR GASKET	VITON

\* In contact with the liquid.

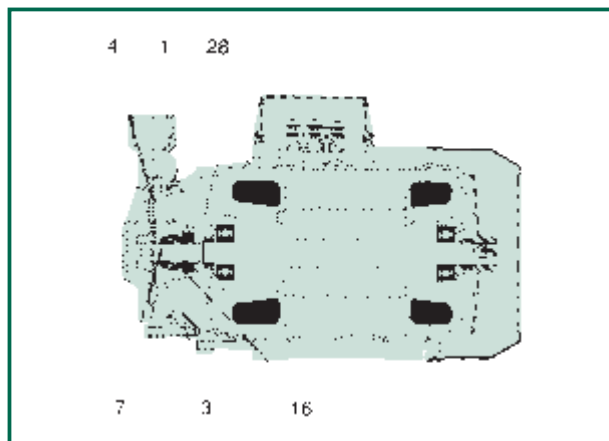

- Operating range: from 1 to 35 l/min with head up to 107 metres
- Liquid quality requirements: clean, free from solids or abrasive substances, non viscous, non aggressive, non crystallized, chemically neutral, close to the characteristics of water.
- Liquid temperature range: from 0°C to +35°C for domestic use (EN 60335-2-41)  
from -10°C to +80°C for other uses
- Maximum ambient temperature: +40°C
- Maximum operating pressure: 12 bar (1200 kPa)
- Installation: fixed in a horizontal position
- Special executions on request: other voltages and/or frequencies

The performance curves are based on the kinematic viscosity values = 1 mm<sup>2</sup>/s and density equal to 1000 kg/m<sup>3</sup>. Curve tolerance according to ISO 9906.

## KP 60/6 - KP 60/12

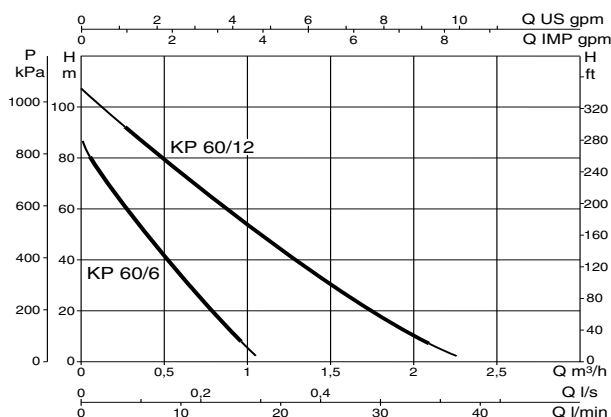
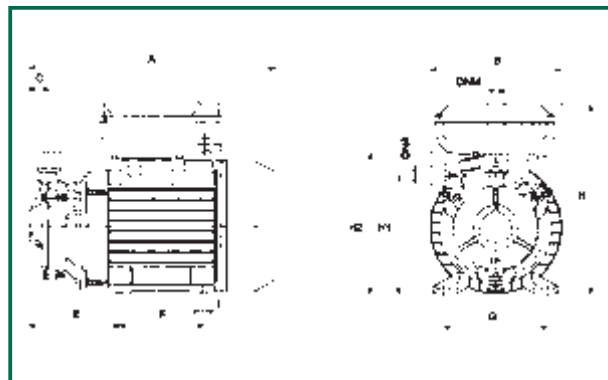

MODEL	A	B	C	E	F	G	I	H	H1	H2	DNA	DNM	PACKING DIMENSIONS			VOLUME m <sup>3</sup>	WEIGHT Kg
													L/A	L/B	H		
KP 60/6 M	262	142	21	96	90	112	7	204	127	151	1/2" G	1/2" G	406	267	402	0,044	8,2
KP 60/6 T	262	142	21	96	90	112	7	173	127	151	1/2" G	1/2" G	406	267	402	0,044	7,9
KP 60/12 M	262	142	20	96	90	112	7	204	126	161	3/4" G	3/4" G	406	267	402	0,044	10,1
KP 60/12 T	262	142	20	96	90	112	7	173	126	161	3/4" G	3/4" G	406	267	402	0,044	10

MODEL	ELECTRICAL DATA										HYDRAULIC DATA (n ≈ 2800 1/min)												
	VOLTAGE 50 Hz	P1 MAX kW	P2 NOMINAL		In A	I st. A	1/min	η max %	cos φ	CAPACITOR		Q											
			kW	HP						μF	Vc	m <sup>3</sup> /h	l/min	0	0,3	0,6	0,9	0,96	1,2	1,5	1,8	2,1	
KP 60/6 M	1x220-240 V ~	0,54	0,37	0,5	2,4	7,7	2800	70,0	0,98	10	450	H (m)	87	57	33	13	9						
KP 60/6 T	3x230-400 V ~	0,52	0,37	0,5	1,8-1	14,5-8,4	2800	71,2	0,72	-	-		107	91	74	58	55	43	29	17	7		
KP 60/12 M	1x220-240 V ~	1,15	0,75	1	5,2	15,8	2800	72,2	0,97	20	450												
KP 60/12 T	3x230-400 V ~	1,12	0,75	1	3,8-2,2	22,1-12,8	2800	77,8	0,80	-	-												